



**GILBERT GRIZZLY MULTIGRIP**  
**VIBRATORY PILE DRIVER**

**GILBERT**





## Diversify your applications

---

Designed for deep foundation construction work, the **Gilbert Grizzly MultiGrip** is the most versatile excavator-mounted vibratory pile driver. Thanks to its side clamp system with **Quick-Change** and **3PAS** technology, it allows precise handling, driving and extraction of all types of piles in a wide variety of applications and industries.

The **Gilbert Grizzly MultiGrip** can easily be installed on any excavator, allowing you to work in confined spaces where the use of conventional piling equipment is difficult. An intuitive control and assistance system allows the operator to achieve maximum potential productivity with a high-level of precision during the entire pile driving process.

**Get a grip on your foundation work with the Gilbert Grizzly MultiGrip.**





# Our technologies

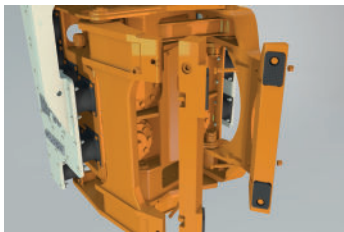

## QUICK-CHANGE

Gilbert's exclusive **Quick-Change system** offers maximum versatility, allowing you to handle all types of piles with attachment. The patented removable side jaws allow you to quickly change between sheet piling/H-beams to pipes or timber piles in no time.



## 3PAS

The **3PAS** technology offers a unique three-point grip configuration. The holding system gives the Gilbert Grizzly MultiGrip a higher maximum holding force and ensures optimal energy transfer from the vibrating unit to the pile, resulting in faster and more efficient driving.



## POWER DRIVE

Thanks to the Power Drive technology, the pile is directly in contact with the vibrating unit of the vibro so there is no energy loss. The driving force is optimally transferred to the pile, which increases the vibration effect in order to accelerate the pile driving process.

## MORE FEATURES

- Sturdy frame built with high quality STRENX steel: lighter and tougher
- Designed for the worker's safety

## CONTROL AND ASSISTANCE SYSTEM

The Gilbert Control and Assistance System supplied with the Grizzly unit connects the pile driver to the hydraulic excavator. Proven advantages of the new IQAN system are: it is very User-Friendly, it registers operation data, it has a bluetooth connectivity and it is remote access. Our Service team can log onto the customer's system from anywhere in the world.

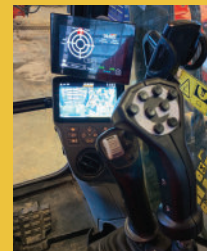

A high-quality ergonomic joystick attaches to the excavator's factory joystick and allows the operator to effectively control all functions of the vibro. The system comes with an Operator Assistance System that indicates the verticality

of the profile using an angle sensor that transmits data in real time to an intuitive screen, providing continuous assistance to the operator. This system is very easy to install on all excavator models. It can also be retrofitted to all existing Gilbert Grizzly Pile Driver operations.

## SEMI-AUTOMATIC FREE FLOATING SYSTEM

The Semi-Automatic Free Floating System assists the operator by reducing pile driving time by up to 40%. It allows the operator to put the excavator bucket cylinder on a floating mode during the pile driving process using the standard joystick. Once the first section of the pile is driven,

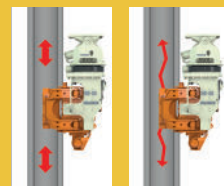

the floating mode will significantly help maintain the initial angle of the pile without having to continuously adjust the movements of the boom throughout the action resulting in a steady pace.

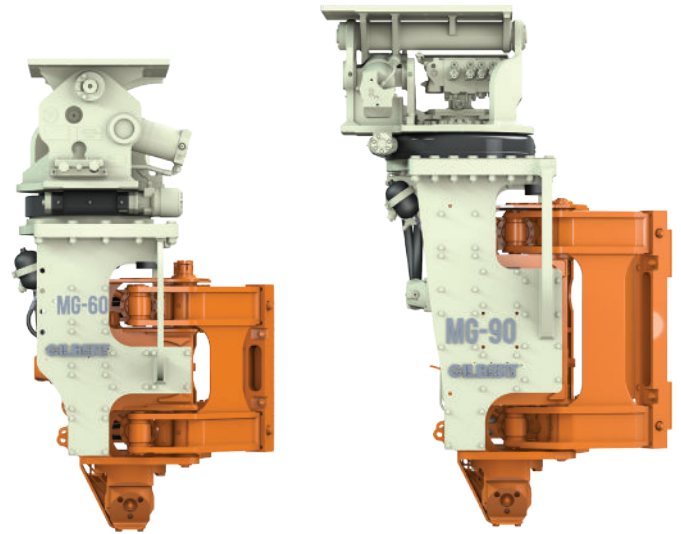

## TECHNICAL SPECIFICATIONS

MODEL	MG-60	MG-90
Excavator Class (Tons)	22-30	30-45
Frequency (RPM)	2800	2800
Centrifugal Force (kN/Tons)	588 / 60	883 / 90
Eccentric moment (kgm/in-lbs)	6,78 / 538	9,33 / 810
Oil Flow (L/min / GPM)	170 / 45	227 / 60
Maximum Pressure Settings (bar/PSI)	310 / 4500	310 / 4500
Amplitude - max. (mm/inch)	9 / 0,35	10,5 / 0,41
Net Weight (kg/Lbs)	2549 / 5620	3275 / 7220
Number of Eccentrics	2	4
Height (mm/Inches)	2108 / 83	2337 / 92
Rotation / Tilt Angle (Degrees)	360 / 40	360 / 40

PATENTED \*Specifications subject to change without notice.

## SUITABLE PILES



### SHEET PILES

Standard arms : Width : 16 to 30 inches, 400 to 750 mm  
U-Pile arms : Width : 16 to 30 inches, 400 to 750 mm



### H-BEAMS

Side Grip : H6 (H180) – H20 (H500)  
Bottom Clamp : H8 (H220) – H20 (H500)



### TUBES & TIMBER PILES

Standard arms : 4 to 18 inches, 100 – 457 mm  
U-Pile Arms : 10 to 24 inches, 250 – 600 mm

### MG-60

Pile length/weight  
6 m (20 ft) / 2350 kg (5181 lbs)  
12 m (40 ft) / 1550 kg (3417 lbs)  
16 m (52 ft) / 1200 kg (2646 lbs)

### MG-90

Pile length/weight  
6 m (20 ft) / 2850 kg (6283 lbs)  
12 m (40 ft) / 1950 kg (4299 lbs)  
16 m (52 ft) / 1350 kg (2975 lbs)

## DIMENSIONS AND WEIGHT FOR TRANSPORT \*

**MG-60** L x l x h (mm/in) : 2489 x 1346 x 1178 / 98 x 53 x 70 Weight (kg/lbs): 3266 / 7200

**MG-90** L x l x h (mm/in) : 2883 x 1270 x 1178 / 113.5 x 50 x 70 Weight (kg/lbs): 3992 / 8800

\* Including mounting plate and transport bracket

1840, boul. Marcotte  
Roberval, Québec Canada  
[www.gilbert-tech.com](http://www.gilbert-tech.com)

T 1 418.275.5041  
F 1 418.275.2624  
[info@gilbert-tech.com](mailto:info@gilbert-tech.com)

