

**SPECIFICATIONS:**

- TORQUE - 25,000 FT-LBF [33.9 kNm]
- DRILLING DEPTH - 55 FT [16.8 m]
- BASE MACHINE - KOMATSU PC 138 USLC-11
- DRILL SPEED - 0 TO 60 RPM
- SPIN OFF - 100 RPM
- CROWD STROKE - 96 IN [2.4 m]
- CROWD FORCE - 24,500 LBF [109 kN] (HYDRAULIC)
- KELLY WINCH - 18,000 LBF [80 kN] (FIRST LAYER)
- SERVICE WINCH - 4,500 LBF [20 kN] (FIRST LAYER, OPTIONAL)
- SIDE TILT - 14 DEG. LEFT/RIGHT
- KELLY BARSET - 6 ELEMENT SQUARE, 2,800 LBM [1,270 kg]
- ATTACHMENT WEIGHT - 6,900 LBM [3,130 kg]
- TRANSPORT WEIGHT - 51,500 LBM [23,360 kg]

\*ALL WEIGHTS ARE APPROXIMATE

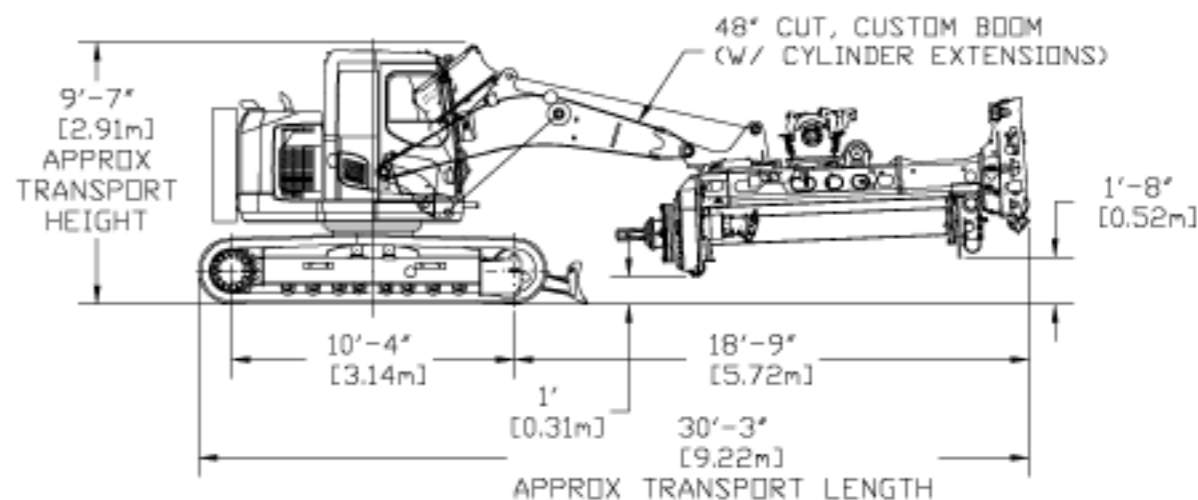
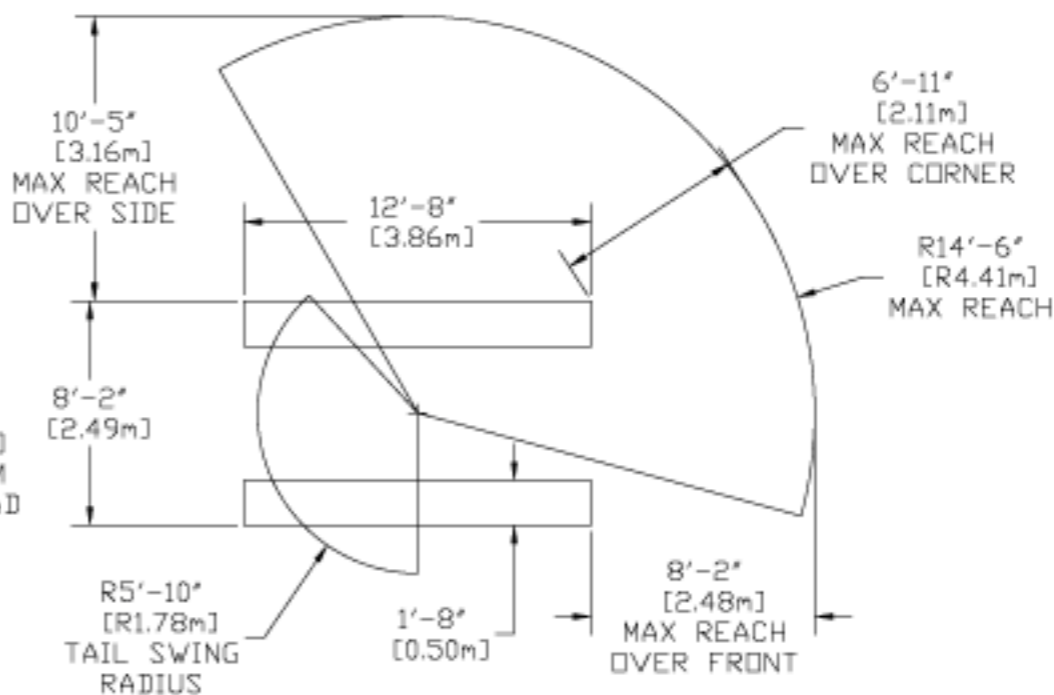
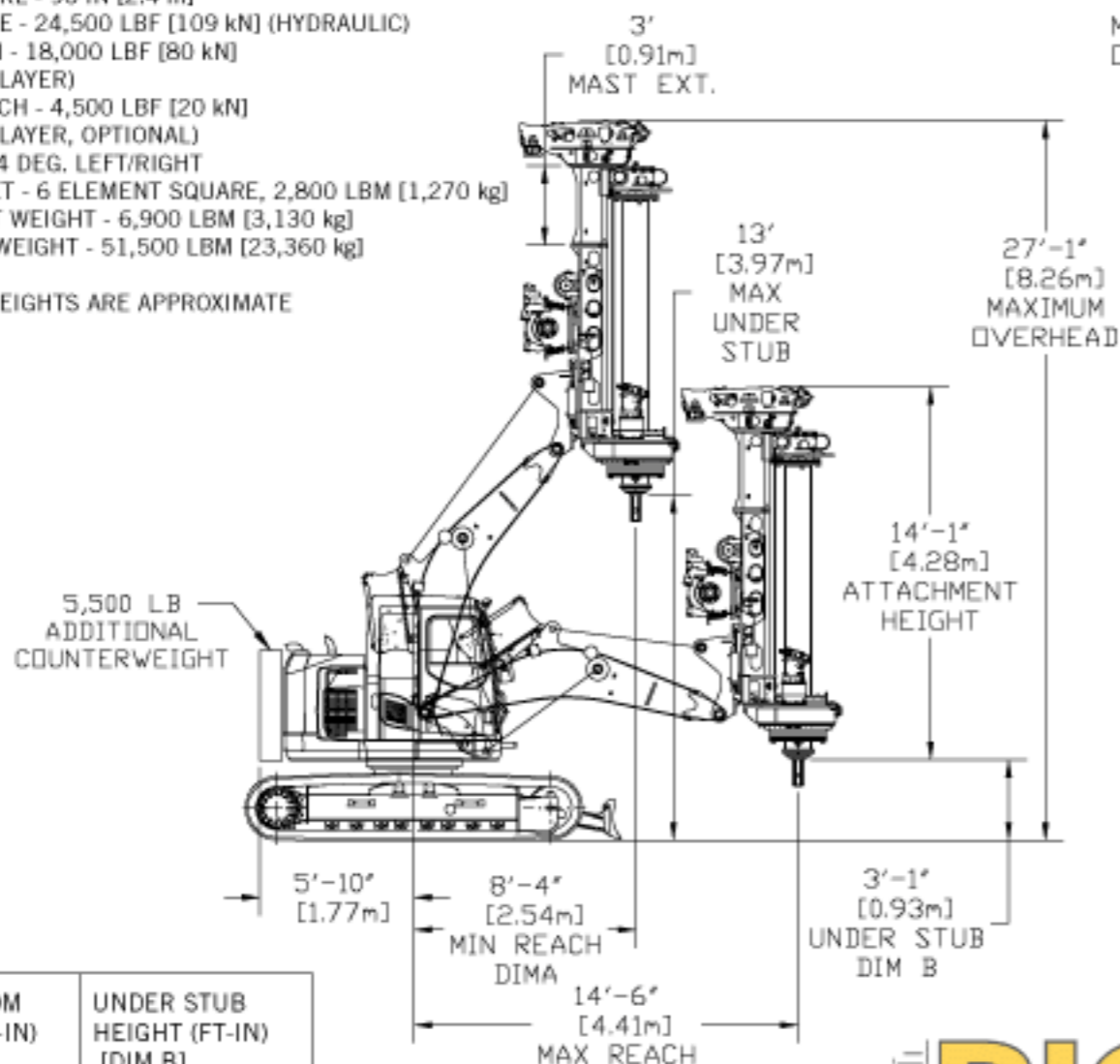

RADIUS FROM CENTER (FT-IN) [DIM A]	UNDER STUB HEIGHT (FT-IN) [DIM B]
8'-4" [2.54 m]	13'-0" [3.97 m]
10' [3.05 m]	12'-0" [3.66 m]
12' [3.66 m]	10'-1" [3.07 m]
14'-6" [4.41 m]	3'-1" [0.93 m]

**RIG-RENTS**  
 WWW.RIG-RENTS.COM PH: (833)RIG-RENT

**TR25-55**  
 ON KOMATSU PC138 USLC-11